

GE Consumer & Industrial  
Appliances

This brochure prepared for:  
**APPLIANCE ASSOCIATES**  
**814 ROMERIA DR**  
**AUSTIN, TX 78757**  
**(512) 454 -5896**

For more information:  
**KIRK RIVAS**  
**814 ROMERIA DR**  
**AUSTIN, TX 78757**  
**(512) 454 -5896**

Additional Business Information  
**[appliance\\_associates@yahoo.com](mailto:appliance_associates@yahoo.com)**



imagination at work



**Model#: HTH17CBTWW**



**Hotpoint® ENERGY STAR® 16.6 Cu.  
Ft. Top-Freezer Refrigerator**

Approx Dimensions (HxDxW):  
64 3/4 in X 31 in X 28 in

- Upfront temperature controls - A simple knob turn regulates interior temperatures with ease
- Adjustable wire shelves - Flexible shelving options can be arranged to handle a variety of foods
- Fixed gallon door bins - Milk and larger items are easily accommodated to allow for more fresh food space
- Crisper drawers - Provides the ideal environment for storing your fruits and vegetables
- Deluxe quiet design - Significantly reduces unnecessary operating noise in the kitchen
- NeverClean™ condenser - Sealed compartment keeps coils clean and simplifies maintenance

**Warranty Information:**

- Parts Warranty : Limited 1-year entire appliance
- Labor Warranty : Limited 1-year entire appliance
- Warranty Notes : See written warranty for full details

**Also Available in:**  
HTH17CBTBB - Black

# HOTPOINT®

## HTH17CBT – Hotpoint® ENERGY STAR® 16.6 Cu. Ft. Top-Freezer Refrigerator

Front View

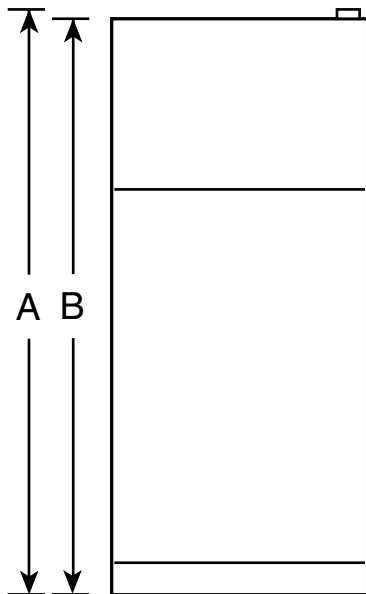

Top View

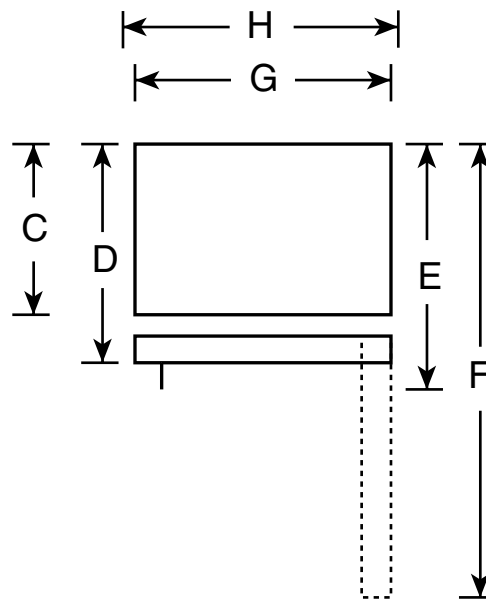

Overall Dimensions	Height to top of hinge (in.) <b>A</b>	<b>64-3/4</b>
	Height to top of case (in.) <b>B</b>	<b>64-1/4</b>
	Height to mid-freezer (in.)	<b>54-3/8</b>
	Case depth without door (in.) <b>C</b>	<b>25-7/8</b>
	Case depth less door handle (in.) <b>D</b>	<b>29-1/8</b>
	Case depth with door handle (in.) <b>E</b>	<b>31</b>
	Depth with fresh food door open 90° (in.) <b>F</b>	<b>54-7/8</b>
	Width (in.) <b>G</b>	<b>28</b>
Air Clearances	Width with door open 90° with door handle (in.) <b>H</b>	<b>30-1/2</b>
	Each side (in.)	<b>3/4</b>
	Top (in.)	<b>1</b>
	Back (in.)	<b>1</b>

**Note:** Before installing, consult installation instructions packed with product for current dimensional data.

**Note: All Top-Freezer No-Frost Right-Hand Refrigerator Doors:** As you face the front of the refrigerator, the handle is on your left and the hinges are on your right.

**All Top-Freezer No-Frost Left-Hand Refrigerator Doors:** As you face the front of the refrigerator, the handle is on your right and the hinges are on your left.





## HTH17CBT – Hotpoint® ENERGY STAR® 16.6 Cu. Ft. Top-Freezer Refrigerator

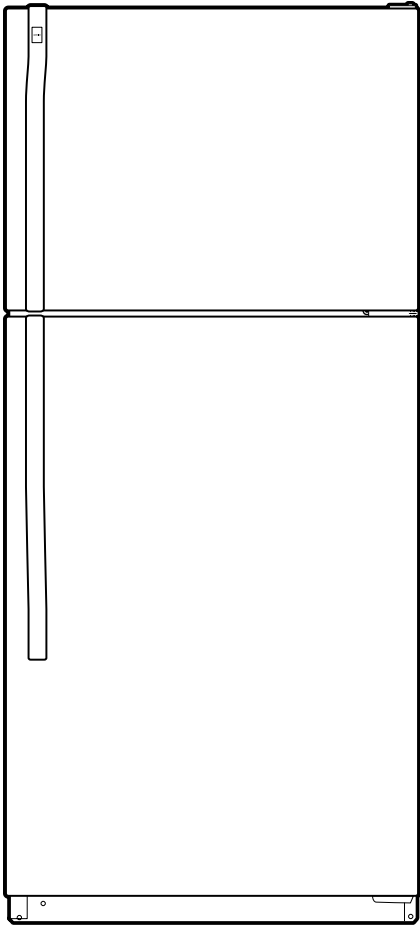

### Features and Benefits

- Upfront temperature controls - Easy-to-use controls are located in an easy-to-reach position
- Adjustable wire shelves - Flexible shelving options can be arranged to handle a variety of foods
- Fixed gallon door shelves - Provides the ideal space for storing gallon containers in the door
- Crisper drawers - Provides the ideal environment for storing your fruits and vegetables
- Deluxe quiet design - Designed to reduce unnecessary sounds in the kitchen
- NeverClean™ condenser - Encased coils take the dirty work out of maintaining your refrigerator
- Model HTH17CBTWW – White
- Model HTH17CBTCC – Bisque

